

HARVEY VOGEL manufacturing CO.



HARVEY VOGEL manufacturing CO.

Custom Metal Stampings and Assemblies



1946

HV produces metal stampings for industrial manufacturers

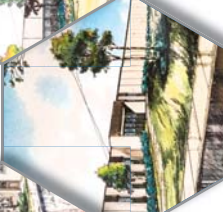

1977

HV moves into a 70,000 sq. ft. building in Minneapolis, MN

2009

Woodbury facility expanded for complex assembly operations

2012

HV expands ever further with a 71,000 sq. ft. facility in Eagan, MN

2018

HV attains AS9100 aerospace & defense certification

1942

Harvey Vogel (HV) opens a 7,000 sq. ft. tool building shop in St. Paul, MN

1954

HV moves into a 20,000 sq. ft. building in Minneapolis, MN

1992

Celebrating 50 years, HV builds a 120,000 sq. ft. state-of-the-art stamping facility in Woodbury, MN

2011

Woodbury facility expanded again to 132,000 sq. ft. to make room for welding and laser systems

2017

Eagan Facility adds powder coating operation

2022

Celebrating 80 years, record breaking sales & shipments, over 300 employees, substantial equipment expansion



HARVEY VOGEL MANUFACTURING CO.

Custom Metal Stampings and Assemblies

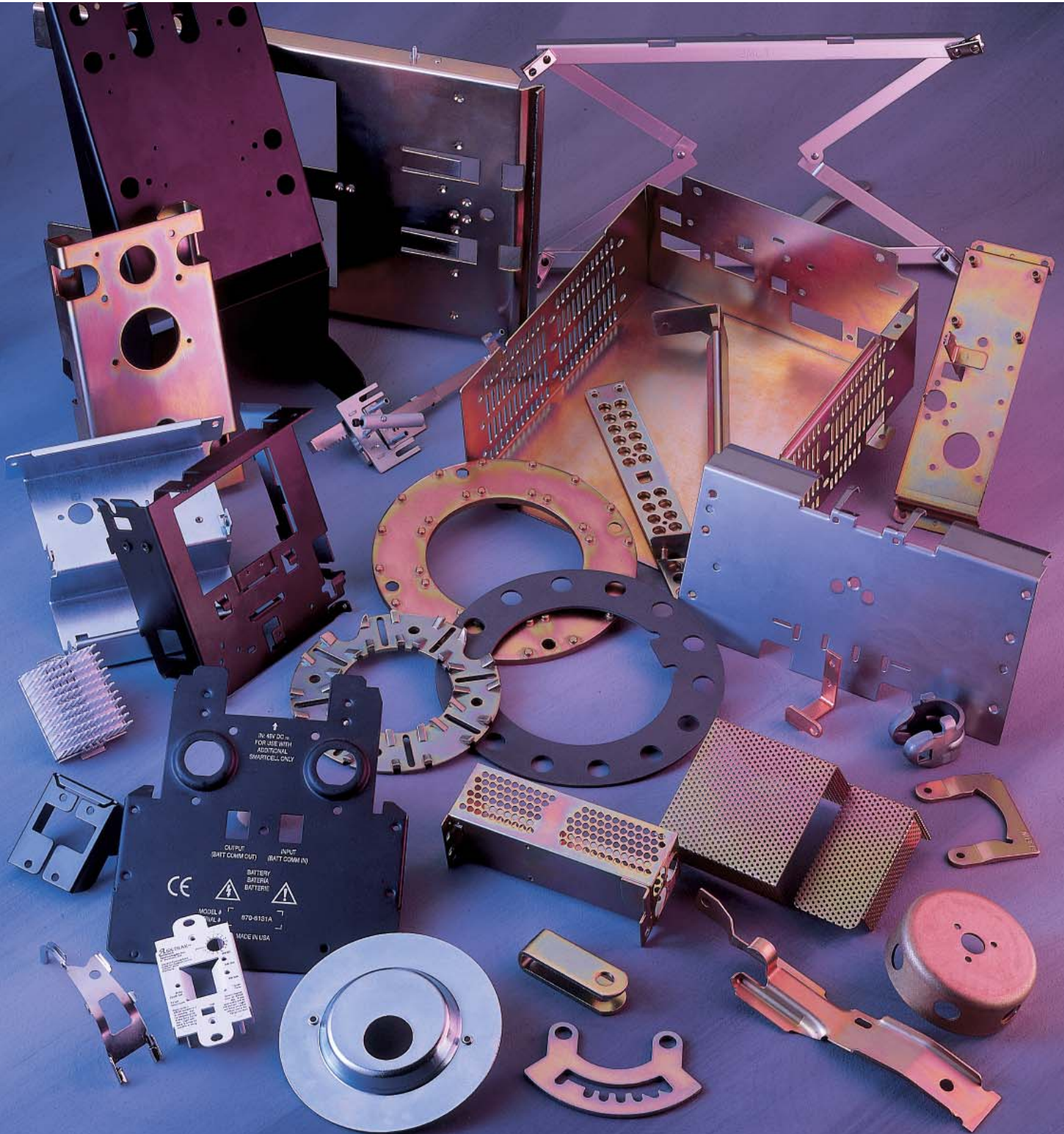

"Your Complete Metal Service Manufacturer"

"WE CAN DO MORE FOR YOU."



With over 80 years of excellence in manufacturing, our team of 300+ dedicated professionals are ready to provide the best solutions to all of your metal stamping and fabrication needs. With state-of-the-art facilities of 132,000 and 71,000 square feet, we house over 200 metal stamping and fabrication machines offering the ultimate in quality, speed, and reliability. Also, with blanking pressure up to 400 tons, HV meets the closest, most exacting tolerances in stampings from one millimeter to 72" x 36", using any stampable material.

Our complete metal service manufacturer capabilities include metal stamping, fabrication, machining, water jet cutting, powder coating, mechanical assembly and more. Whatever metal forming need you have, "Harvey Vogel can do more for you!"

The Harvey Vogel Advantage

- The expert in the metal stamping industry
- AS9100, ISO 9001 and ISO 14001 certified
- Specialize in high quality, more complex, tight tolerance and appearance oriented metal parts
- Strong quality assurance program and systems
- Complete in-house design, engineering and tool room support and capabilities
- Electronic print transfer and advanced CAD/CAM design capabilities
- World class process design, production work cells and assembly lines
- Continual process improvement and cost reduction programs
- Just in time, kanban, 3rd party warehouse and vendor managed inventory programs
- Value added secondary and assembly services
- Fully automated powder coating paint line
- Your Complete Metal Service Manufacturer

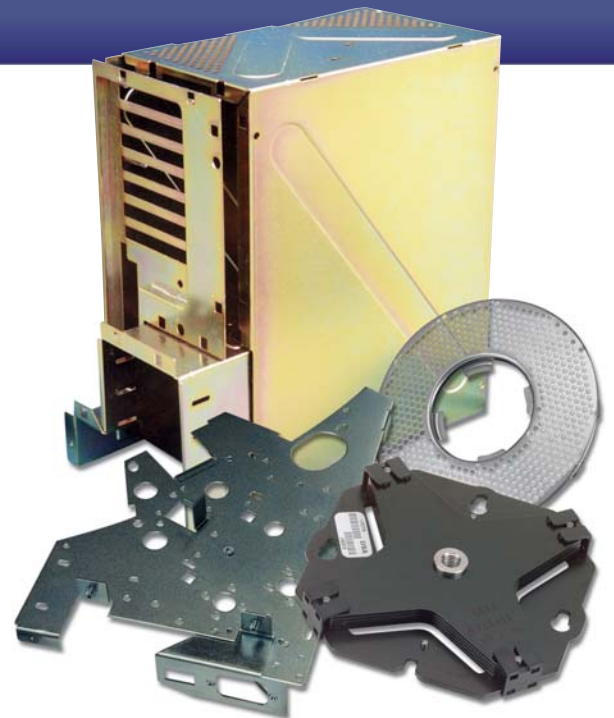

Harvey Vogel is an AS9100, ISO 9001 and 14001 Certified Company

Prototype Through Volume

HV works with you to decide the type of tooling and production method that best meets your volume requirements and cost/benefit needs.

Lesser Volume / Rapid

- Samples or prototypes
- Typically less than 5,000 parts annually
- Manufacture with lasers, turrets, water jet machines, and press brakes
- No tooling costs, less value in piece price



Short to Medium Run

- Typically 5,000 to 40,000 parts annually
- Manufacture with stage tools built and maintained in house for life of part
- Usually one tool for each operation (e.g., blank, form, pierce, form)
- Shared die sets to reduce tool cost
- Less expensive tools, lower piece price

We can meet all of your short to medium run needs with low cost short-run tooling.

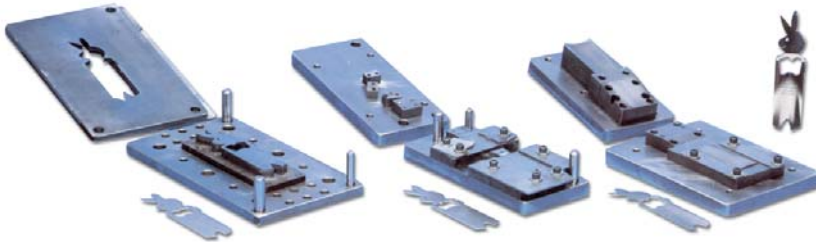

Examples of short-run, semi-permanent blank, pierce and form tooling.



Longer Run Volume

- Typically 40,000 parts or more annually
- Manufacture with progressive tools built and maintained in house
- One tool for all operations
- Final part produced with each stroke of the press
- More expensive tool, lower piece price

Example of a strip layout from progressive tooling.

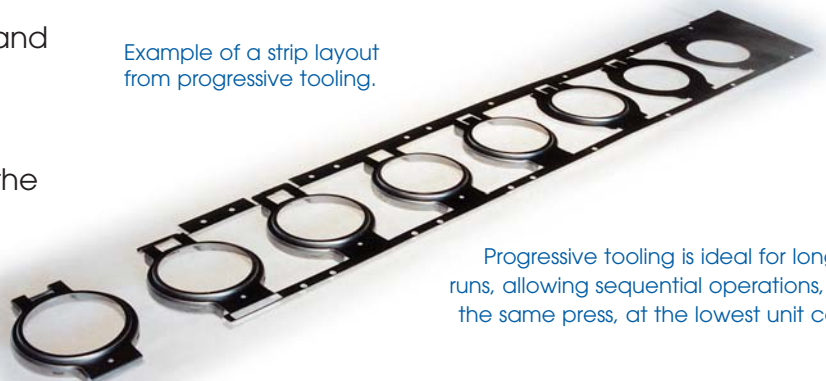

Progressive tooling is ideal for longer runs, allowing sequential operations, on the same press, at the lowest unit cost.

Harvey Vogel adds value to everything we do...

Assembly

Painting

Plating

E-Coat/Anodize

Waterjet

Leveling

Deburring

Box Builds

Machining

Hardware Installation

Powder Coating (NEW!)

Heat Treating

Spot Welding

Tig & Mig Welding

Silkscreening

Double Disc Grinding

Labeling

Bar Coding

Kanban, JIT & 3rd Party Warehousing

All of your metal stamping and assembly needs from one source



"Your Complete Metal Service Manufacturer"



Harvey Vogel is an AS9100, ISO 9001 and 14001 Certified Company

HARVEY VOGEL MANUFACTURING CO.
425 Weir Drive • Woodbury, MN 55125-1200
(651) 739-7373 • FAX (651) 739-8666

www.harveyvogel.com

HARVEY VOGEL MANUFACTURING CO.

Quality Metal Stampings
and Fabrications from Prototype
through Volume Production.

- 2 facilities totalling 203,000 square feet
- Over 200 punch presses (ranging from 10 to 400 tons) to produce stampings from one millimeter to 72" x 36"
- Short run, medium run and progressive stampings
- Fabrication, laser, machining and waterjet cutting
- Stamp all material types (steel, stainless steel, aluminum, yellow metals)
- Powder coating and mechanical assembly
- Just in time, kanban, 3rd party warehouse and vendor managed inventory programs available
- Ship worldwide
- AS9100, ISO 9001 and ISO 14001 certified



2935C 12/22



HARVEY VOGEL MANUFACTURING CO.

Custom Metal Stampings and Assemblies



HV Facilities and Equipment

Two State-of-the-Art Facilities / 203,000 Square Feet / 300+ Employees

Utilizing hundreds of metal manufacturing machines to produce stampings and fabrications from one millimeter to 36" x 96" while maintaining the closest, most exacting tolerances using any stampable material.

Metal Stamping • Fabrication • Machining • Assembly • Powder Coating

COMPLETE TOOL ROOM FACILITIES: 15+ Experienced Toolmakers – Dedicated CNC Machining Centers (3 Axis with 20 Tool Changer) – **5 Wire EDM Machines** – Complete Programming Center – 1 Conventional EDM Machine – Vertical and Horizontal Milling Machines with Digital Readouts – 4 Tool Room Lathes – 5 Surface Grinders – Drill Presses – 150-Ton Hydraulic Arbor Press – 3-Ton Bridge Crane – Blanchard Grinder.

PUNCH PRESS DEPARTMENT: Over 200 Presses, Capacity Ranging From 10 to 400 Tons, Equipped with Quick Change Set Up, Air Ejection, Pneumatic Cushions, Coil Reels and Straightening Feeders, Including:

1 – Brown & Boggs 400 Ton Straight Side Press. Bed Size 48" x 96", Speed 30 To 60 SPM Fully Integrated Die Change and Feed Line System, Maximum Coil ¼" x 32" x 12,000 lbs.

1 – Bliss 300-Ton Straight Side Press. Bed Size 54" x 96", Speed 30 to 120 SPM Fully Integrated Die Change and Feed Line System, Maximum Coil ¼" x 32" x 8,000 lbs.

1 – Bliss 150-Ton Straight Side Press. Bed Size 36" x 60", Speed 50 to 120 SPM Fully Integrated Die Change and Feed Line Systems, Maximum Coil 3/16" x 18" x 5,000 lbs.

1 – Multi Press 150 Ton Hydraulic Press; 1 Greenard 75-Ton Hydraulic Press. For Draws up to 6 inches.

FABRICATING AND PROTOTYPES: 4 Lasers: (2 Trumpf L3030 6,000 Watt Fiber Laser with Dedicated 8-Pallet Tower System, 2 Trumpf L3030 4,000 Watt Lasers with 8-Pallet Tower System, and 1 Mazak Super Turbo X Mark II; 1,500 Watts, 4 x 8 Sheet Capacity) – 2 Turrets (3 Amada Vipros 255 Turret Presses with Automated Load/Unload) – 15 Press Brakes (3) 8', (6) 10' and (6) 12' with Micro Processor Controls Plus 5 with CNC Axis Back Gage.

SECONDARY OPERATIONS DEPARTMENT: Drill Presses and Tapping Machines for Drilling, Reaming, Tapping, Countersinking and Counterboring Holes **WELDING:** 4 Spot Welders – **TIG/MIG Welding – 600 Amp High Speed Fanuc 5 Axis Robotic Weld Cell (30" x 40" Capacity)** – Arc Welding – Component Assemblies **LEVELING:** 5 Straightener/Leveling Machines – 2 Hammerle TRM 50/750 Precision Flat Metal Roll Leveling Machine **MACHINING:** 12 Haas CNC Machining Centers (Including New VF4 and DM-2).

DEBURRING DEPARTMENT: 4 Vibrating Units – Belt Sanders – Grinders – 4 Timesaver Sanders with Automatic Parts Washer/Rust Inhibitors – FT-32 Flo Thru Tumbling Machine – Straightliner – Surface Finishing Machine w/ Fiber/Wire/Abrasive Capabilities – Parts Washer.

INSPECTION DEPARTMENT: Coordinate Measuring Machines CMMs Hexagon Global 5 Green 7.10.7 and Brown & Sharpe Global Image 575. 2 1/2 D Planar InspecVision System. Coordinate Inspection Machine (CIM) with Hewlett Packard HP85 Computer – Micrometers – Indicators – Hite Indicator – Height Gauges – Gauge Blocks – Surface Plates – Optical Comparator – Rockwell – Hardness Tester – Go-NoGo Gauges – Optical Profile Projector (20X), Virtek Laser / QC Scanning System – 4 Camera 100% Inspect Vision System for Assembly or Inspection. **Keyence Image Dimension Measurement System.**

POWDER COATING: 470 FT Automated Line - 5-Step Cleaning Process - Environmental Room & Touch Up Batch Booth

ASSEMBLY DEPARTMENT: 16 Automatic Hardware Insertion Machines – 4 Riveting and Staking Machines - D4 Atlantic Barcode, Label Machines – 3 Aro Drilling Machines – 1 Proconier Drilling Machine – Numerous Machines/Facilities Automated for Project Specific.

MATERIALS WAREHOUSE: 71,000 Square Foot Warehouse. Over 1,500 Different Types and Gauges of Materials Certified to Physical and Chemical Properties. Isolated and Secured Storage Area for Special Materials – 3 Shears, Capacity 12 Feet, ¼" Thick.

CUSTOMER MANAGED INVENTORY WAREHOUSE: Customer Part Stock System for Just In Time and KanBan Delivery to Customer Dock or Warehouse.

SHIPPING: 12 Ship Docks – Air – Parcel Post – Truck – YRC – UPS – Fed Ex – 5 Counting Scales (Small Parts Plus 5,000 lb. Scale) – Complete Inventory of Packaging Materials – 3 Delivery Trucks (including 1 Semi-Trailer) – Bar Coding – Auto-Bagger.

HARVEY VOGEL MANUFACTURING CO.

425 Weir Drive Woodbury, MN 55125-1200 www.harveyvogel.com
(651) 739-7373 • FAX (651) 739-8666



Harvey Vogel is an AS9100, ISO 9001 and 14001 Certified Company



HV Overview

Harvey Vogel Manufacturing Co. (HV) is a complete metal service manufacturer that was founded in 1942. HV has two facilities totaling 203,000 square feet of manufacturing space and employs over 300 people running three shifts a day seven days a week.

Manufacturing Capabilities

- Metal stamping
- Sheet metal fabrication
- Laser cutting
- Water jet cutting
- CNC machining
- TIG welding
- Robotic welding
- Mechanical assemblies
- Powder coating
- Complete secondary services

Production Machinery

- Over 200 stamping presses (from 10 to 400 tons)
- 2 Fiber optic lasers (6,000 watt)
- 2 CNC laser cutting systems (4,000 watt)
- 3 CNC laser automation systems (24 x 7)
- 3 CNC turret punch presses
- 1 WARDJet water jet cutter
- 4 Hydraulic presses for draws up to 6"
- 15 CNC controlled press brakes with 5 axis gauging
- 12 CNC machining centers
- 5 wire EDM machines
- Multiple MIG/TIG/Arc/Spot welders
- Stock reels and feed line equipment
- 5 Hamerlee/Kohler leveling systems
- 5-stage automated powder coat line

Certifications



AS9100
AEROSPACE
& DEFENSE



ISO9001
QUALITY
MANAGEMENT



ISO14001
ENVIRONMENTAL
MANAGEMENT



HV Overview

Manufacturing Services

- Design recommendations
- Cost saving techniques
- Rapid prototyping
- In-house tool & die
- Hardware insertion
- Part leveling, grinding & sanding
- Auto sealed air foam-in-bag packaging
- Part deburring & cleaning
- Powder coating

Stocking Programs

- KanBan
- Just in time
- Dock-to-stock
- Pull systems
- Customer-site managed inventory

Quality Assurance Capabilities

- First article inspection reports
- Receiving inspection data
- In-process/final inspection data
- Calibration database
- Corrective/preventative action
- CMMS & optical comparators
- PPAP and capability studies
- Statistical Process Control
- AS9100 Certified

Software & Accepted Electronic Files

- Key Creator - Cadkey
- SolidWorks
- Auto-Cad
- Pro-Engineer
- IGES / DXF files

All of your metal stamping and assembly needs from one source

HARVEY VOGEL MANUFACTURING CO.

Quality Metal Stampings and Fabrications from Prototype through Volume Production.

- 2 facilities totalling 203,000 square feet
- Over 200 punch presses (ranging from 10 to 400 tons) to produce stampings from one millimeter to 72" x 36"
- Short run, medium run and progressive stampings
- Fabrication, laser, machining and waterjet cutting
- Stamp all material types (steel, stainless steel, aluminum, yellow metals)
- Powder coating and mechanical assembly
- Just in time, kanban, 3rd party warehouse and vendor managed inventory programs available
- Ship worldwide
- AS9100, ISO 9001 and ISO 14001 certified



"Your Complete Metal Service Manufacturer"

HARVEY VOGEL MANUFACTURING CO.
425 Weir Drive • Woodbury, MN 55125-1200
(651) 739-7373 • FAX (651) 739-8666

www.harveyvogel.com



Harvey Vogel is an AS9100, ISO 9001 and 14001 Certified Company



2935C 12/22



HARVEY VOGEL MANUFACTURING CO.

Custom Metal Stampings and Assemblies



Markets Served

Aerospace

Military

Medical

Agricultural &

Construction Machinery

Computer

Recreational Equipment

Industrial Automation

Gaming

Small Engine

Lawn & Garden

Telecommunications

Data Storage

Networking Equipment

2nd & 3rd Tier Automotive

Contract Manufacturing

Fabrication

Lighting

Banking

Food Service Equipment

Business Systems

Robotics/Automation



"Your Complete Metal Service Manufacturer"

Manufacturing Processes



Stamping

Short-Run (Stage Tool)

- Low tooling cost
- Typically 5,000 to 50,000 EAU
- One time tooling charge
- One tool each operation

Progressive Tool

- Higher tooling cost
- Typically 50,000 EAU & above
- One tool all operations



Fabrication

Lasers

Turrets

Press Brakes

- No tooling cost
- Typically under 5,000 EAU
- Prototypes
- Start up
- Lower volumes



Machining

Vertical CNC Machining Centers

- Tighter tolerances
- Spindle speeds up to 12,000 RPM
- Two heights to 20"
- Thru spindle coolant



Waterjet Cutting

5 Axis Waterjet Cutting

- Thickness up to 6"
- Sheet size up to 6' x 12'
- Nearly all materials

All of your metal stamping and assembly needs from one source



HARVEY VOGEL MANUFACTURING CO.

Quality Metal Stampings and Fabrications from Prototype through Volume Production.

- 2 facilities totalling 203,000 square feet
- Over 200 punch presses (ranging from 10 to 400 tons) to produce stampings from one millimeter to 72" x 36"
- Short run, medium run and progressive stampings
- Fabrication, laser, machining and waterjet cutting
- Stamp all material types (steel, stainless steel, aluminum, yellow metals)
- Powder coating and mechanical assembly
- Just in time, kanban, 3rd party warehouse and vendor managed inventory programs available
- Ship worldwide
- AS9100, ISO 9001 and ISO 14001 certified



**"Your Complete Metal
Service Manufacturer"**



Harvey Vogel is an AS9100, ISO 9001 and 14001 Certified Company

HARVEY VOGEL MANUFACTURING CO.
425 Weir Drive • Woodbury, MN 55125-1200
(651) 739-7373 • FAX (651) 739-8666

www.harveyvogel.com



2935C 12/22



Parts and Projects Like Yours...

World Class Manufacturing

Harvey Vogel Manufacturing is recognized as a highly diverse supplier of top quality metal stampings, fabrications and assemblies from start-up applications to Fortune 500 companies.

With over 200 presses, up to 400 tons, Harvey Vogel can accommodate any metal stamping need from short and long run to simple and complex parts and assemblies. Our innovative production designed work cells with conveyors and assembly lines produce parts more efficiently, at the lowest cost.



Automotive Service Equipment

- Operations to manufacture are blank, form, heat treat, shot blast, plate and plastisol handle
- Tight tolerance parts with heat treat



ATM Cash Dispenser

- 31 total pieces of hardware
- 9 different types are inserted post plate
- Very tight tolerances



After Market Recreational Equipment

- Fishing boat anchor
- Waterjet cut, form, plate
- 3/8" and 1/2" aluminum



Computer Assembly

- 5-piece assembly, very tight tolerances
- Leveling to .005 across length of part
- Metallurgical testing performed
- Coordination of many outside suppliers and processes



Lottery Chassis

- 7-piece assembly, mild steel with spot welds
- Design input from inception for cost reduction
- Stage tool incorporated to minimize labor costs
- Weight reduction by use of tooled features
- Custom packaging to eliminate cost and waste

"Your Complete Metal Service Manufacturer"

Parts and Projects Like Yours...



Medical Equipment

- Medical cart for capturing patient information
- Very tight tolerances
- Aesthetic requirements & paint
- Powder coat in-house



Food Service Equipment

- 18" x 20" plate used for keeping food warm in the fast food industry
- Plate is aluminum leveled to 0.20 flat across length of part
- Plate has a highly cosmetic black anodized surface



Agriculture Industry

- Multi-part assembly
- TIG weld
- Complex forms
- Aesthetic requirements & paint
- Powder coat in-house



2nd and 3rd Tier Automotive

- Shifter assembly for military vehicle
- Parts manufactured using stage tools
- 100% cost reduction through process improvements
- Powder coat in-house

All of your metal stamping and assembly needs from one source



HARVEY VOGEL MANUFACTURING CO.

Quality Metal Stampings and Fabrications from Prototype through Volume Production.

- 2 facilities totalling 203,000 square feet
- Over 200 punch presses (ranging from 10 to 400 tons) to produce stampings from one millimeter to 72" x 36"
- Short run, medium run and progressive stampings
- Fabrication, laser, machining and waterjet cutting
- Stamp all material types (steel, stainless steel, aluminum, yellow metals)
- Powder coating and mechanical assembly
- Just in time, kanban, 3rd party warehouse and vendor managed inventory programs available
- Ship worldwide
- AS9100, ISO 9001 and ISO 14001 certified



"Your Complete Metal Service Manufacturer"

HARVEY VOGEL MANUFACTURING CO.
425 Weir Drive • Woodbury, MN 55125-1200
(651) 739-7373 • FAX (651) 739-8666

www.harveyvogel.com



Harvey Vogel is an AS9100, ISO 9001 and 14001 Certified Company



2935C 12/22



HARVEY VOGEL manufacturing co.

Custom Metal Stampings and Assemblies



Prototypes

Your partner for precision metal fabricated assemblies

In the process of developing new or improving existing products, your engineering team needs capable partners that are integral to your team. Delivering results in a fast-paced schedule is the key to the success of your project. Harvey Vogel is the ideal partner to become an extension of your team as we can deliver accurate prototypes in as little as **24 to 48 hours**.



Supporting Your Engineering

Harvey Vogel will work closely with your team through the design phase to provide components that meet the most exacting form, fit, and function requirements. Our experience will support a Value Analysis/Value Engineering (VAVE) process that balances performance and cost. The payback to you through this process will be recognized through your product launch and production.

Prototype Capabilities

Our customers benefit from our experience as well as the tools that we have in our tool box. Utilizing multiple CAD platforms on the front-end, we are able to easily work with your designs to help establish a process.

- **Laser**
- **Water Jet**
- **Turret**
- **Press Brake**
- **Assembly**
- **Welding**
- **Powder Coating**



"Your Complete Metal Service Manufacturer"

Prototypes

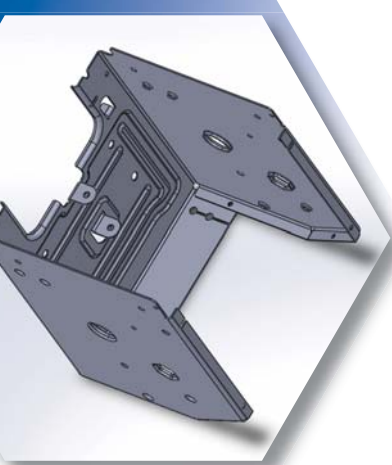

Case Study 1 Gear Case

Our customer was in process of a complete redesign of their power equipment product line. They were on an aggressive timetable and needed to prototype most of the new designs to prove them out. Our engineering team played an integral role in the VAVE process to ensure that the case could be manufactured cost effectively. The size of this part is 14" x 11" x 11".



Case Study 2 Rotating Base

Our customer needed a new design for a rotating base for an existing product. The initial parts were completed in three days to support required product testing. The testing process identified some issues with the existing design and the part was redesigned. Harvey Vogel made new parts in an equally short timeframe to support additional testing and acceptance to support the product launch. The size of this part is 10" x 6" x 6".

All of your metal stamping and assembly needs from one source



HARVEY VOGEL MANUFACTURING CO.

**Quality Metal Stampings
and Fabrications from Prototype
through Volume Production.**

- 2 facilities totalling 203,000 square feet
- Over 200 punch presses (ranging from 10 to 400 tons) to produce stampings from one millimeter to 72" x 36"
- Short run, medium run and progressive stampings
- Fabrication, laser, machining and waterjet cutting
- Stamp all material types (steel, stainless steel, aluminum, yellow metals)
- Powder coating and mechanical assembly
- Just in time, kanban, 3rd party warehouse and vendor managed inventory programs available
- Ship worldwide
- AS9100, ISO 9001 and ISO 14001 certified



**"Your Complete Metal
Service Manufacturer"**

HARVEY VOGEL MANUFACTURING CO.
425 Weir Drive • Woodbury, MN 55125-1200
(651) 739-7373 • FAX (651) 739-8666

www.harveyvogel.com



Harvey Vogel is an AS9100, ISO 9001 and 14001 Certified Company



2935C 12/22



Performance Powder Coating

Fully Integrated Manufacturing Saves Time & Money

Harvey Vogel's new state-of-the-art powder coating system saves time and money on your projects that require a painted finish. Outsourced painting requires packing and shipping parts to another facility. It can take weeks for the parts to return for final assembly and shipping.

In-house powder coating enables HV to ship product days and even weeks faster. The other advantage of a full-service operation is the cost savings. Controlling all the aspects of your project under one roof allows us to price aggressively.

Get high-quality parts faster and at a great price with Harvey Vogel Manufacturing Co., your full-service metal manufacturer.

System Overview

- In-Line Overhead Monorail Powder Coating System
 - 470-foot long variable speed conveyor
- 5-Stage Stainless Steel Washer
 - Product size up to 12" wide X 48" high X 48" long
- In-Line Dry Oven
- Parker Ionics Q-Flo-4500 Powder Booth with Accessories
 - 2-person booth with manual guns
- Parker Ionics Q-Flo-1500 Powder Booth with Accessories
 - 1-person booth with manual gun for samples/prototypes
- Environmental Room for Powder Booths
 - 25' X 36'
- In-Line Cure Oven



Finishes for Every Part



Medical Chassis



Agriculture Flow Control

Precision Masking & Plugging | Difficult Angles | On-Site Quality Control | Color Matching | Various Finishes



Military Communication



Packaging Machine - Cover

All of your metal stamping and assembly needs from one source



HARVEY VOGEL MANUFACTURING CO.

**Quality Metal Stampings
and Fabrications from Prototype
through Volume Production.**

- 2 facilities totalling 203,000 square feet
- Over 200 punch presses (ranging from 10 to 400 tons) to produce stampings from one millimeter to 72" x 36"
- Short run, medium run and progressive stampings
- Fabrication, laser, machining and waterjet cutting
- Stamp all material types (steel, stainless steel, aluminum, yellow metals)
- Powder coating and mechanical assembly
- Just in time, kanban, 3rd party warehouse and vendor managed inventory programs available
- Ship worldwide
- AS9100, ISO 9001 and ISO 14001 certified



**"Your Complete Metal
Service Manufacturer"**

HARVEY VOGEL MANUFACTURING CO.
425 Weir Drive • Woodbury, MN 55125-1200
(651) 739-7373 • FAX (651) 739-8666

www.harveyvogel.com



Harvey Vogel is an AS9100, ISO 9001 and 14001 Certified Company



2935C 12/22



HARVEY VOGEL MANUFACTURING CO.

Custom Metal Stampings and Assemblies



Assembly

Your partner for complex assemblies

Harvey Vogel now adds even more value by assembling your complex stampings and components into more advanced sub-modules that can then be easily assembled right into your final OEM product. Save time and money with assemblies from Harvey Vogel.

From a Few Components to Hundreds

At Harvey Vogel we can simply assemble a few parts for you or complete a Bill of Materials (BOM) of hundreds of different components. Our strong project management teams allows us to build, procure and assemble various metal, plastic, wiring and other components to create your final product with the highest quality. We can also finish your parts to meet any of your requirements. This greatly simplifies your process by using only Harvey Vogel instead of hassling with potentially hundreds of vendors.

Our Assembly Experience

Harvey Vogel is a leader in the manufacturing of difficult metal stampings and assemblies for a wide variety of industries. With over 75 years of excellence in manufacturing, our team of over 300 dedicated professionals is ready to assemble your stampings, fabrications and purchased components into your final creation. Whatever type of assembly, sub-module or value add you need, Harvey Vogel can pull it all together for you!



"Your Complete Metal Service Manufacturer"

Assembly



Case Study 1 Automated Teller Machine

This precision assembly consists of 77 metal stampings, 34 purchased components, and hundreds of hardware pieces using over 20 vendors. The end result is a sophisticated ATM. Harvey Vogel stamps the complex metal components and assembles them into a sub module saving the customer thousands of dollars and significantly reducing the number of vendors required.

Core services provided:

- Metal Stampings & Fabrication
- Welding, Painting & Plating
- Purchased Components:
 - Plastic
 - Slides
 - Locks
 - Custom Packaging
- Final Assembly



Case Study 2 Medical Transfer Cart

Completely designed by Harvey Vogel, the final product consists of 22 metal components and 15 purchased components from 13 separate vendors. The end product is a transfer cart for distributing medical supplies and medicine in hospitals. Harvey Vogel ships all the final carts to the end customer saving time and money.

Core services provided:

- Metal Stampings & Fabrication
- Powder Coating
- Purchased Components:
 - Plastic
 - Rubber Bumpers
 - Casters
 - Hardware & Hinges
- Final Assembly

All of your metal stamping and assembly needs from one source



HARVEY VOGEL MANUFACTURING CO.

Quality Metal Stampings and Fabrications from Prototype through Volume Production.

- 2 facilities totalling 203,000 square feet
- Over 200 punch presses (ranging from 10 to 400 tons) to produce stampings from one millimeter to 72" x 36"
- Short run, medium run and progressive stampings
- Fabrication, laser, machining and waterjet cutting
- Stamp all material types (steel, stainless steel, aluminum, yellow metals)
- Powder coating and mechanical assembly
- Just in time, kanban, 3rd party warehouse and vendor managed inventory programs available
- Ship worldwide
- AS9100, ISO 9001 and ISO 14001 certified



"Your Complete Metal Service Manufacturer"

HARVEY VOGEL MANUFACTURING CO.
425 Weir Drive • Woodbury, MN 55125-1200
(651) 739-7373 • FAX (651) 739-8666

www.harveyvogel.com



Harvey Vogel is an AS9100, ISO 9001 and 14001 Certified Company



2935C 12/22



Contact Personnel

In order to facilitate the most efficient handling of any requests, we ask that you contact the following personnel regarding those subjects indicated. Thank you so much for choosing Harvey Vogel Manufacturing Co.

EXECUTIVE AND FINANCE

Bob Verhey
President & CEO

Dave Daley
Vice President of Finance

SALES, QUOTATIONS and PRICING

- Matt Mountain**, Vice President of Sales & Marketing
- Bob Sproull**, Sales Managing Director
- John Griswold**, Sales Account Engineer/Marketing Manager
- Kasey Kruger**, Sales Account Engineer
- Mike Higgins**, Sales Account Engineer
- Scott Peterson**, Sales Account Engineer
- Steve Longhenry**, Sales Account Engineer

- Vu Nguyen**, Sales Engineer
- Ted VanRanst**, Process Engineer Managing Director
- Diana Ous**, Process Engineer Associate
- Loni Reule**, Credit & Invoicing

OPERATIONS CUSTOMER SERVICE, PRODUCTION SCHEDULING and DELIVERIES

- Marnie Dantzer**, Vice President of Operations
- Jake Darsow**, Materials Managing Director
- Brian Linehan**, Production Control Managing Director
- Andy Larson**, Production Planner/Outside Services Coordinator

- Chris Husnick**, Customer Service Manager
- Karen Cordova**, Customer Service/Production Planner
- Cynthia Songster**, Sales Administrative & Customer Service Associate

QUALITY CONTROL

- Darren Dershem**, Vice President of Quality & Continuous Improvement
- Tim Keeley**, Quality Control Manager
- Jeff Staton**, Manufacturing Quality Engineer

- Cynthia Vang**, Manufacturing Quality Engineer
- Luke Smith**, Manufacturing Quality Engineer
- Yang Ly**, Manufacturing Quality Engineer

ENGINEERING and MANUFACTURING

- Nic Gianino**, Vice President of Manufacturing & Engineering
- Kent Stepan**, Director of Engineering
- Tony Kunkel**, Director of Manufacturing, Maintenance & Facilities
- Jay Case**, Manufacturing Director

- John Nosbusch**, Director of Manufacturing/HV West
- Lee Huberty**, Manufacturing Manager/HV West
- Wess Buren**, Shipping Manager

“Your Complete Metal Service Manufacturer”





HARVEY VOGEL MANUFACTURING CO.

Custom Metal Stampings and Assemblies



hvt HARVEY VOGEL MANUFACTURING CO.
Custom Metal Stampings and Assemblies

Aerospace

Reach new heights with precision stampings from HV

AS9100 CERTIFIED

Aerospace products require a mix of precision and responsive requirements that make them some of the most challenging projects. Our extensive list of hand tools lead to precision parts that keep the world's military flying. Harvey Vogel offers you a breadth of experience and capabilities to meet these challenging requirements, while providing on-time delivery.

Prototype to Production
From revolutionary products to improving your supply chain for high-quality stampings, Harvey Vogel meets your needs. Our experienced team of process manufacturing, from product development through production.

Our Aerospace Experience
Harvey Vogel is a leader in the manufacturing of stampings and assemblies for the aerospace and defense industries. We build complex assemblies in a variety of materials and finishes, including engine parts, fuel tanks, and control systems. Many of these parts have tight tolerances and are highly visible. Our ability to add value by providing complete components and assemblies makes Harvey Vogel your ideal choice to handle your aerospace product needs.

Your Complete Metal Service Manufacturer

hvt HARVEY VOGEL MANUFACTURING CO.
Custom Metal Stampings and Assemblies

Agriculture & Mining

Your partner for precision metal fabricated assemblies

Harvey Vogel understands the challenge of manufacturing products for the agriculture and mining industries. Our products meet the toughest environments where you, our client, operate. Harvey Vogel has the experience and capability to support your needs, whether developing a new product or producing a replacement component.

From Design to Production
From revolutionary products to improving your supply chain for high-quality stampings, Harvey Vogel meets your needs. Our experienced team of process manufacturing, from product development through production.

Our Agriculture & Mining Experience
Harvey Vogel is a leader in the manufacturing of stampings and assemblies for agriculture and mining equipment. Products that incorporate Harvey Vogel components include the most demanding conditions to ensure long-term performance. Our ability to add value by providing complete components and assemblies makes Harvey Vogel your ideal choice for your agriculture and mining equipment.

Your Complete Metal Service Manufacturer

hvt HARVEY VOGEL MANUFACTURING CO.
Custom Metal Stampings and Assemblies

Business & Entertainment

Your partner for precision metal fabricated assemblies

Harvey Vogel components and assemblies take your business to a new level. A mix of materials and finishes are available.

- Financial Transactions (ATM's, check processing, cash registers)
- Point of Sale (Retailing, specialty vending, gift registers)
- Gaming (Cafe machines and lottery machines)

Harvey Vogel brings the expertise and assets to provide total solutions for stamping and assembly for business and entertainment products.

From Prototype to Production
From revolutionary products to improving your supply chain for high-quality stampings, Harvey Vogel meets your needs. Our experienced team of process manufacturing, from product development through production.

Our Business & Entertainment Experience
Harvey Vogel is a leader in the manufacturing of stampings and assemblies for business & entertainment products. Products that incorporate Harvey Vogel components include the most demanding conditions to ensure long-term performance. Our ability to add value by providing complete components and assemblies makes Harvey Vogel your ideal choice for your business & entertainment products.

Your Complete Metal Service Manufacturer

hvt HARVEY VOGEL MANUFACTURING CO.
Custom Metal Stampings and Assemblies

Computers & Electronics

Energize your products with our precision metal assemblies

Complex and electronic products require a mix of precision and responsive requirements that make them some of the most challenging projects. The combination of our hand tools lead to precision parts that keep the world's electronics running. Harvey Vogel offers you a breadth of experience and capabilities to meet your challenging quality requirements, while providing on-time delivery.

Prototype to Production
From revolutionary products to improving your supply chain for high-quality stampings, Harvey Vogel meets your needs. Our experienced team of process manufacturing, from product development through production.

Our Computers & Electronics Experience
Harvey Vogel is a leading manufacturer of stampings and assemblies for computer and electronic products. Products that incorporate Harvey Vogel components include the most complex and electronic technologies, including complete box build capabilities. Our ability to add value by providing complete components and assemblies makes Harvey Vogel your ideal choice for your computer and electronic products.

Your Complete Metal Service Manufacturer

hvt HARVEY VOGEL MANUFACTURING CO.
Custom Metal Stampings and Assemblies

Food & Beverage

Cheers to Harvey Vogel

Harvey Vogel's experience in the food and beverage industry includes components and assemblies used in industrial and consumer equipment, point of sale products, food service and retail food services. These products require precision and consistency in a variety of materials. Harvey Vogel offers you a breadth of experience and capabilities to meet these challenges, while providing exceptional quality and on-time delivery.

Prototype to Production
From revolutionary products to improving your supply chain for high-quality stampings, Harvey Vogel meets your needs. Our experienced team of process manufacturing, from product development through production.

Our Food & Beverage Experience
Harvey Vogel is a leader in the manufacturing of stampings and assemblies for the food and beverage industry. Many of these parts have tight tolerances and are highly visible. Our ability to add value by providing complete components and assemblies makes Harvey Vogel your ideal choice to handle your food and beverage product needs.

Your Complete Metal Service Manufacturer

hvt HARVEY VOGEL MANUFACTURING CO.
Custom Metal Stampings and Assemblies

Industrial & Commercial

Enhance your products with our complex stampings & assemblies

Industrial and commercial products require a mix of precision and responsive requirements that make them some of the most challenging projects. The combination of our hand tools lead to precision parts that keep the world's industry running. Harvey Vogel offers you a breadth of experience and capabilities to meet these challenging requirements, while providing on-time delivery.

Prototype to Production
From revolutionary products to improving your supply chain for high-quality stampings, Harvey Vogel meets your needs. Our experienced team of process manufacturing, from product development through production.

Our Industrial Experience
Harvey Vogel is a leader in the manufacturing of stampings and assemblies for industrial and commercial products. Products that incorporate Harvey Vogel components include the most demanding conditions to ensure long-term performance. Our ability to add value by providing complete components and assemblies makes Harvey Vogel your ideal choice to handle your industrial product needs.

Your Complete Metal Service Manufacturer

hvt HARVEY VOGEL MANUFACTURING CO.
Custom Metal Stampings and Assemblies

Medical

The specialist for precision stampings

Developing and producing medical products can be challenging. Cost and accuracy must be balanced with the stringent quality requirements required by your customers. Harvey Vogel has the experience and capability to support your needs. When it comes to metal stamping, we're a specialist Harvey Vogel.

From Design to Production
From revolutionary products to improving your supply chain for high-quality stampings, Harvey Vogel meets your needs. Our experienced team of process manufacturing, from product development through production.

Our Medical Experience
Harvey Vogel is a leading manufacturer of stampings and assemblies for medical products. Products that incorporate Harvey Vogel components include the most demanding conditions to ensure long-term performance. Our ability to add value by providing complete components and assemblies makes Harvey Vogel your ideal choice for your medical product needs.

Your Complete Metal Service Manufacturer

hvt HARVEY VOGEL MANUFACTURING CO.
Custom Metal Stampings and Assemblies

Transportation

Move forward with high-quality metal stampings and fabrications

Harvey Vogel's experience in the transportation sector includes components and assemblies used in automotive, trucking and industrial equipment. The combination of our hand tools lead to precision parts that keep the world's transportation running. Harvey Vogel offers you a breadth of experience and capabilities to meet your challenging requirements, while providing on-time delivery.

Prototype to Production
From revolutionary products to improving your supply chain for high-quality stampings, Harvey Vogel meets your needs. Our experienced team of process manufacturing, from product development through production.

Our Transportation Experience
Harvey Vogel is a leader in the manufacturing of stampings and assemblies for the transportation industry. Many of these parts have tight tolerances and are highly visible. Our ability to add value by providing complete components and assemblies makes Harvey Vogel your ideal choice to handle your transportation product needs.

Your Complete Metal Service Manufacturer

hvt HARVEY VOGEL MANUFACTURING CO.
Custom Metal Stampings and Assemblies

Recreation

Ride to the top with precision stampings and assemblies from HV

Many recreational products require a mix of precision and responsive requirements that make them some of the most challenging projects. The combination of our hand tools lead to precision parts that keep the world's recreation running. Harvey Vogel offers you a breadth of experience and capabilities to meet these challenging requirements, while providing on-time delivery.

Prototype to Production
From revolutionary products to improving your supply chain for high-quality stampings, Harvey Vogel meets your needs. Our experienced team of process manufacturing, from product development through production.

Our Recreation Experience
Harvey Vogel is a leader in the manufacturing of stampings and assemblies for the recreation industry. Many of these parts have tight tolerances and are highly visible. Our ability to add value by providing complete components and assemblies makes Harvey Vogel your ideal choice to handle your recreation product needs.

Your Complete Metal Service Manufacturer

hvt HARVEY VOGEL MANUFACTURING CO.
Custom Metal Stampings and Assemblies

Military

Because the best defense is a good offense

AS9100 CERTIFIED

Experience dating back to 1945, the most advanced facilities and equipment available, and highly skilled engineers and technicians make us the ideal choice to think your military projects forward.

World Class Manufacturing

- Short run and progressive stamping
- Water jet cutting
- Fabrication
- Machining
- Aerospace Powder Coating
- Laser
- Laser Powder Coating

Inventory Your Lead Times

- Just in Time
- Vendor managed inventory
- Just party warehouse
- Kanban

Your Complete Metal Service Manufacturer



“Our most important mission is complete customer satisfaction!”

- Bob Verhey, President & CEO

hvt HARVEY VOGEL MANUFACTURING CO.
Custom Metal Stampings and Assemblies

Recreation

Ride to the top with precision stampings and assemblies from HV

Many recreational products require a mix of precision and responsive requirements that make them some of the most challenging projects. The combination of our hand tools lead to precision parts that keep the world's recreation running. Harvey Vogel offers you a breadth of experience and capabilities to meet these challenging requirements, while providing on-time delivery.

Prototype to Production
From revolutionary products to improving your supply chain for high-quality stampings, Harvey Vogel meets your needs. Our experienced team of process manufacturing, from product development through production.

Our Recreation Experience
Harvey Vogel is a leader in the manufacturing of stampings and assemblies for the recreation industry. Many of these parts have tight tolerances and are highly visible. Our ability to add value by providing complete components and assemblies makes Harvey Vogel your ideal choice to handle your recreation product needs.

Your Complete Metal Service Manufacturer

hvt HARVEY VOGEL MANUFACTURING CO.
Custom Metal Stampings and Assemblies

Military

Because the best defense is a good offense

AS9100 CERTIFIED

Experience dating back to 1945, the most advanced facilities and equipment available, and highly skilled engineers and technicians make us the ideal choice to think your military projects forward.

World Class Manufacturing

- Short run and progressive stamping
- Water jet cutting
- Fabrication
- Machining
- Aerospace Powder Coating
- Laser
- Laser Powder Coating

Inventory Your Lead Times

- Just in Time
- Vendor managed inventory
- Just party warehouse
- Kanban

Your Complete Metal Service Manufacturer

Your Complete Metal Service Manufacturer



Custom Metal Stampings & Assemblies

Your Complete Metal Service Manufacturer

Metal Stamping
Sheet Metal Fabrication
Laser Cutting
CNC Machining
Water Jet Cutting
TIG Welding
Robotic Welding
Mechanical Assemblies
Powder Coating
Complete Secondary Services

HARVEY VOGEL manufacturing co.

425 Weir Drive Woodbury, MN 55125-1200
(651) 739-7373 • FAX (651) 739-8666

www.harveyvogel.com



Harvey Vogel is an AS9100, ISO 9001
and 14001 Certified Company